



Stepper Motor Driver VID6608

General Description

The quad stepping motor driver VID6608 is a monolithic CMOS device intended to be used as an interface circuit to ease the use of the stepper motor VID29-XX. It is specifically designed for applications in the car dashboard. The circuit allows the user to drive two motors as it contains two identical drivers on the same chip.

The driver circuit converts a pulse train $f(scx)$ into a current level sequence sent to the motor coils. This sequence is used to produce the micro stepping movement of the motor. Each inner driver in the chip generates 2 sequent logic pulse signals and provides shaft stepping angle resolution $1/12^\circ$.

Features

- Generates micro steps
- Glitch filters on all inputs
- $V_{DD} = 4.5$ to $5.5V$
- Low EMI emission

Applications

Analogue Instrumentation

- Motor car instrumentation
- Car dashboard
- Nautical instrumentation
- Aeronautical instrumentation

Micro robotics

- Appliance controls
- Devices for medical analysis





Typical Operating Configuration

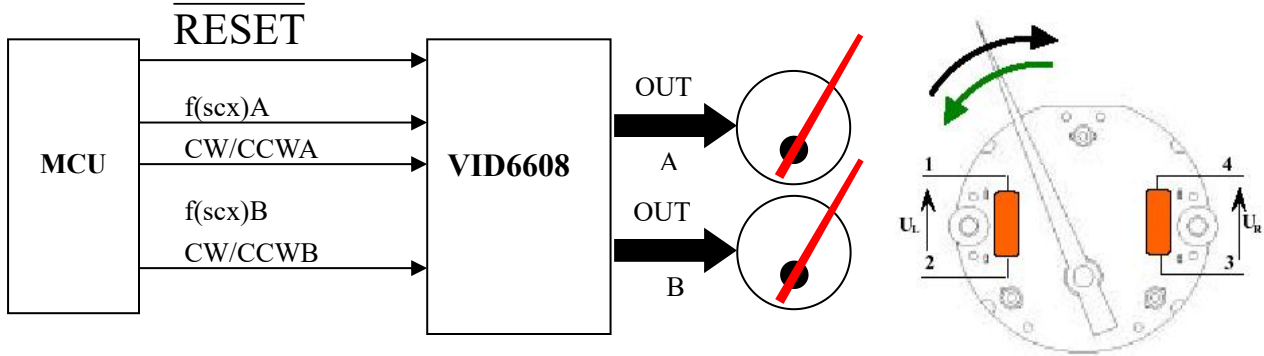

Pin Configuration

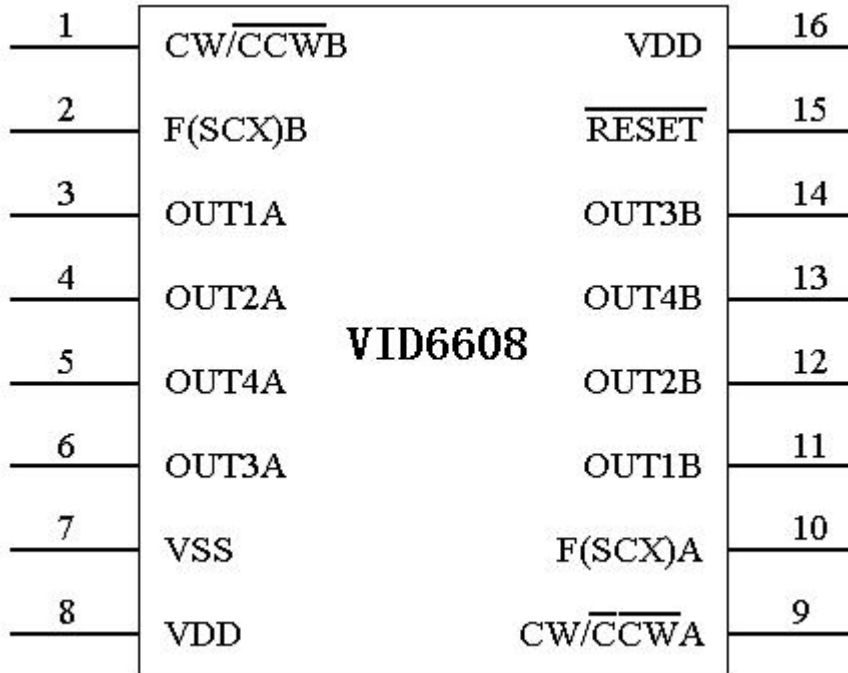

Pin Description

Unused inputs must always be tied to a defined logic voltage level .

Pin Number SOP – 16 version	Name	I/O	Function
8/16	V _{DD}	V	Positive supply voltage
7	V _{SS}	V	Negative supply voltage
2/10	f(scx) A/B	I	Stepping frequency; Driver A / B
1/9	CW/CCW A/B	I	Direction of rotation; Driver A / B
15	RESET	I	Reset for the two drivers
3/11	OUT 1A/1B	O	Coil output 1; Driver A / B
4/12	OUT 2A/2B	O	Coil output 2 ;Driver A / B
6/14	OUT 3A/3B	O	Coil output 3 ;Driver A / B
5/13	OUT 4A/4B	O	Coil output 4 ;Driver A / B

Operating Conditions

Parameter	Symbol	Test Conditions	Min	Typ	Max	Units
Operating temperature	T _A		-40		+105	°C
Thermal impedance	R _{th i-a}	SOP package		80		°C/W
Supply voltage	V _{DD}		4.5	5	5.5	V
Input voltage at any pin	V _{IN}		V _{SS}		V _{DD}	V

Load Characteristics

Parameter	Symbol	Test Conditions	Min	Typ	Max	Units
Coil resistance	R _{B25}	VID29-XX, T _A =25°C	270	280	290	Ω
	R _{B-40}	VID29-XX, T _A =-40°C	190			Ω
	R _{B105}	VID29-XX, T _A =105°C	340			Ω
Phase inductance	L ₂₅	VID29-XX, T _A =25°C		0.4		H

Electrical Characteristics

$V_{DD} = 4.5\sim 5.5V$, $T_A = -40\sim 105^{\circ}C$, unless otherwise specified

Parameter	Symbol	Test Conditions	Min	Typ	Max	Units
Typical supply current	I_C	$V_{DD}=5V$, $\omega = 200^{\circ}/S$, $T_A=25^{\circ}C$, $R_{B25}=280\Omega$		76		mA
Worst case supply current	$I_{C_{MAX}}$	$V_{DD}=5.5V$, $RESET=V_{SS}$, $T_A=-40^{\circ}C$, $R_{B-40}=190\Omega$			200	mA
Quiescent supply current	I_{CC}	All inputs at V_{DD} or V_{SS} , no load			300	μA
Low level input voltage	V_{IL}	$V_{DD}=4.5\sim 5.5V$	V_{SS}		1.35	V
High level input voltage	V_{IH}	$V_{DD}=4.5\sim 5.5V$	3.15		V_{DD}	V
Input leakage	I_{IN}	$V_{IN}=V_{SS}$ or V_{DD}	-10		10	μA

Timing Characteristics

$V_{DD} = 4.5\sim 5.5V$, $T_A = -40\sim 105^{\circ}C$, t_{rise} and $t_{fall} \leq 20ns$, input signal swing V_{SS} to V_{DD}

Parameter	Symbol	Test Conditions	Min	Typ	Max	Units
Signal pulse width	t_w	high or low	450			ns
Input frequency	$f(scx)$	Driver input limit 1.1 MHz Motor speed limit ($=600^{\circ}/s$)			1.1 7.2	MHz KHz
Setup time to $f(scx)$	t_s	high or low	100			ns
RESET release time to $f(scx)$	t_{rr}		100			ns

Delay Timing Waveforms

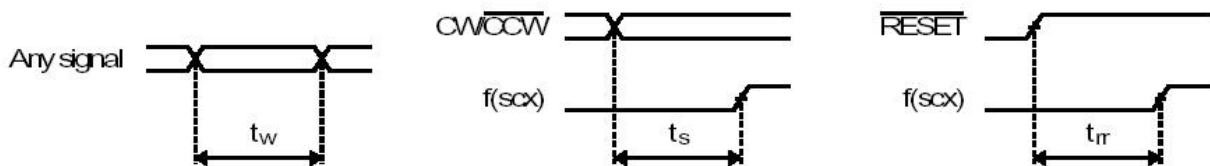

Absolute Maximum Ratings

Parameter	Symbol	Conditions
Voltage V_{DD} to V_{SS}	V_{DD}	-0.3~+6V
Voltage at any pin to V_{DD}	V_{MAX}	+0.3V
Voltage at any pin to V_{SS}	V_{MIN}	-0.3V
Current at OUTs 1-4	I_{OUTMAX}	$\pm 35mA$
Max. junction temperature	T_j	150°C
Operating temp. range	T_A	-40~+105°C
Storage temp. range	T_{STO}	-65~+125°C

Handling Procedures

Stresses beyond these listed maximum ratings may cause permanent damage to the device. Exposure to conditions beyond specified operating conditions may affect device reliability or cause malfunction.

The device has built-in protection against high static voltages or electric fields; however, anti-static precautions must be taken as for any other CMOS component. Unless otherwise specified, proper operation can only occur when all terminal voltages are kept within the supply voltage range. Unused inputs must always be tied to a defined logic voltage level unless otherwise specified.

Circuit Protections

To filter fast voltage transients, it is highly recommended to connect one 100nF ceramic capacitors to the power supply pins, as close as possible to the IC.

Moreover, to protect the chip against latch-up, a 5uF capacitor per motor connected should be added. Thus, for 2 motors, typically a 22uF capacitor must be used, either electrolytic or tantalum. Note this capacitor can be placed close to the voltage regulator.

Recommended Power Up

In order to power up the circuit in a defined manner, it is recommended to keep the RESET input low while the V_{DD} voltage is raising. After a delay of about 1ms, the RESET can be released (i.e. set high). Depending on the micro controller used, an external pull-down resistor might be required to properly set the RESET state at low during the start-up.

 <p>Hong Kong VID Company Limited Vehicles Instrumentation Devices</p>	<p>Stepper Motor Driver (For two motors)</p>	<p>Type:VID6608 Revision: 1 Page:6/7</p>
--	---	--

Functional Description

The rising edge of the f(scx) input signal moves the rotor by one micro step.

The input signal "CW/CCW" (clockwise / counterclockwise) controls the direction of rotation of the motor.

Input Glitch Filter & Level Shifter

All logic inputs of this driver are armed with a glitch filter to avoid erroneous information due to spikes and glitches on the input signal lines. All negative or positive pulses of less than 20 ns width are ignored.

A minimum signal pulse width (positive or negative) of 450 ns guarantees correct function over the full temperature range.

All logic inputs also feature a level shifter, which allows for operation of the circuit at a higher supply voltage (V_{DD}) than the circuits driving the inputs. This is in order to drive the VID motors at a higher torque level.



Package Dimensions

SOP - 16

