

DETAIL A  
SCALE 4 : 1

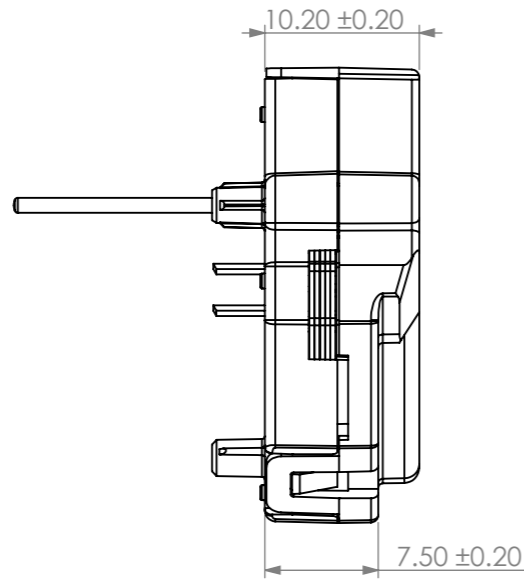
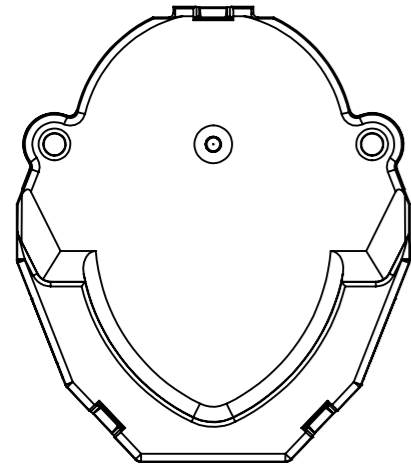
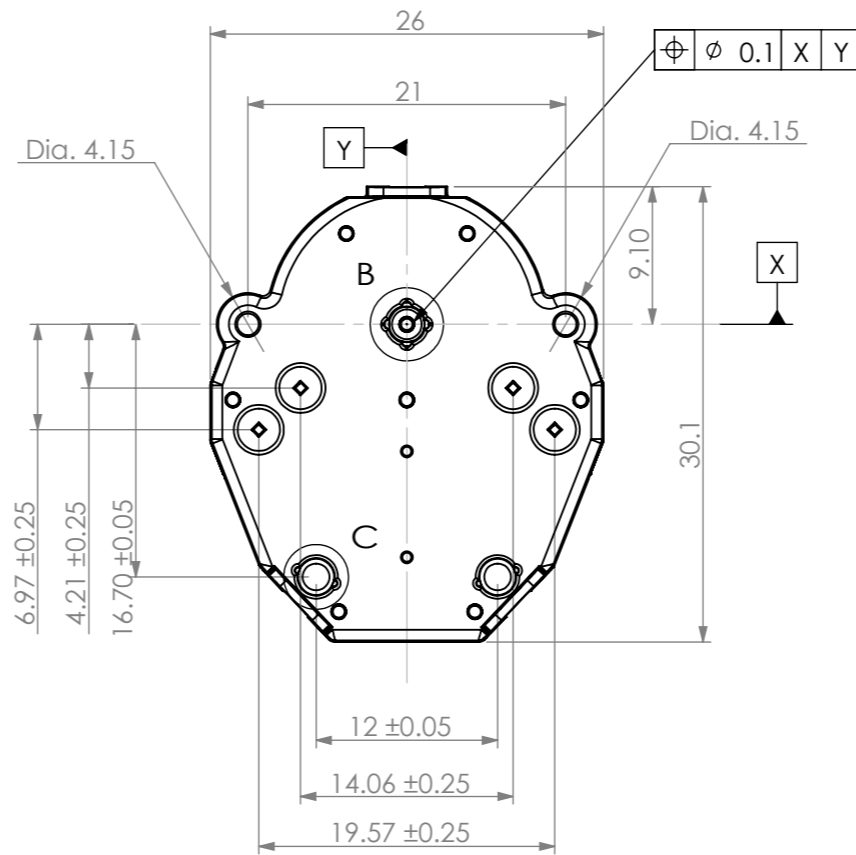
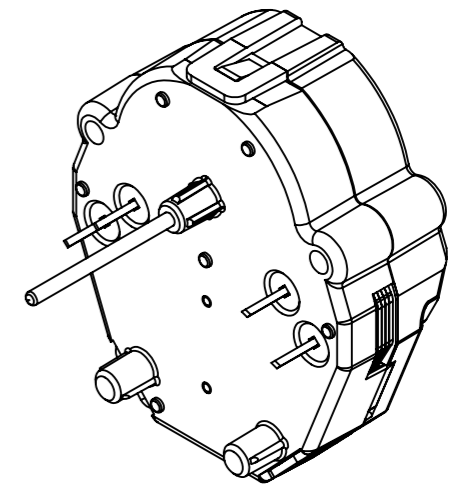
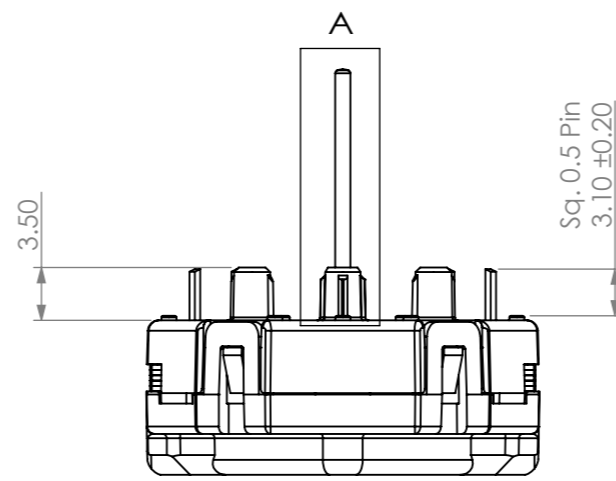

SPECIFICATIONS:

Housing:  
- Material : PC  
- Colour : Black

Shaft :  
- Material : Stainless Steel  
- Axial force (stake-on) : 130N  
- Axial pull out force : 70N  
- Radial force : 12N  
- External torque : 30 mNm max.  
- Rotational Angle : 315 max.

Electric Properties :  
- Electric Pin : Tin plated CP wire

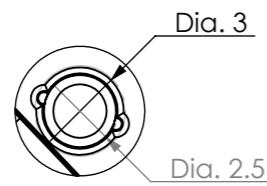

DETAIL C  
SCALE 4 : 1

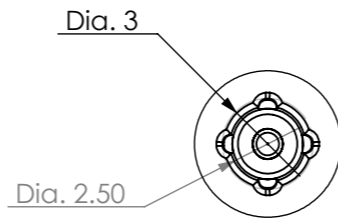

DETAIL B  
SCALE 4 : 1

Drawing No. RD-DWA-V38-05V-A16	Revision A16	Material	Date of Issue 2024-3-13
Product/Part Name VID38-05V	Product/Part No. VID38-05V	JDE No.	Size A3
Project Title VID38-05V Step Motor		Unit mm	Approve by
		<b>Hong Kong VID Company Limited</b>	
Tolerance unless specified Dimension in mm x.x = +/- 0.10    x.xx = +/- 0.03 Angle in degree x.x = +/- 1°    x.xx = +/- 0.5°			