

D (10 : 1)

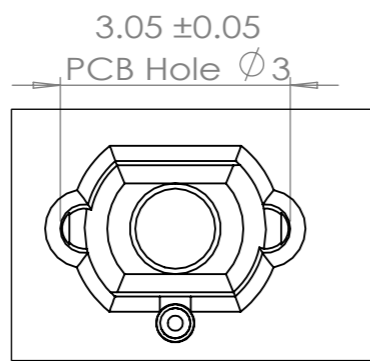

C (10 : 1)

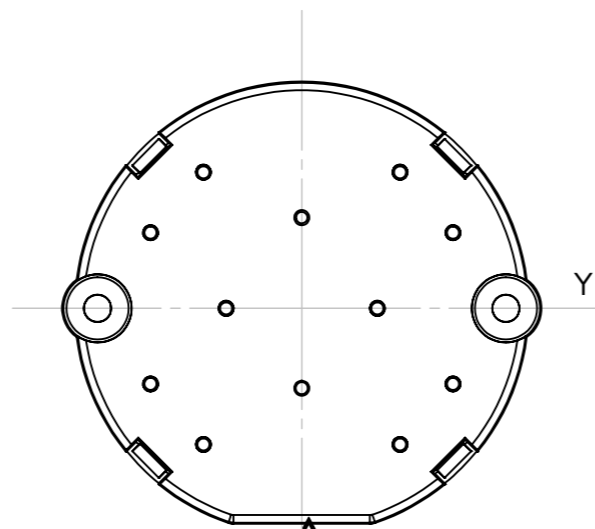

A

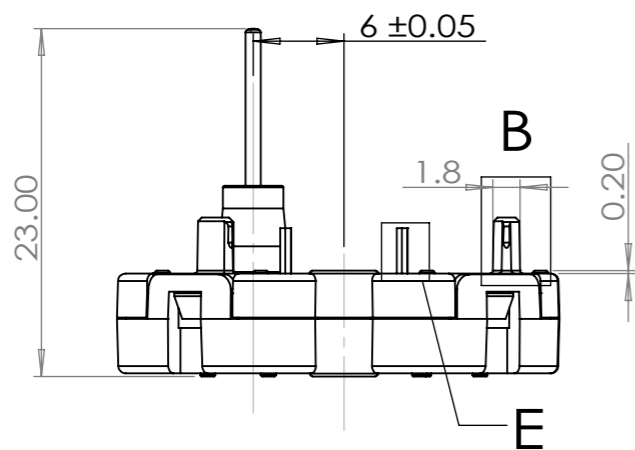

B

E

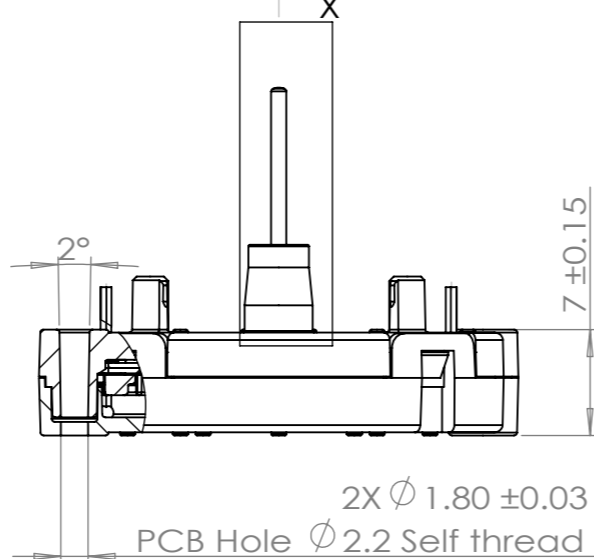

2X ϕ 1.80 \pm 0.03

PCB Hole ϕ 2.2 Self thread screw PB2.0

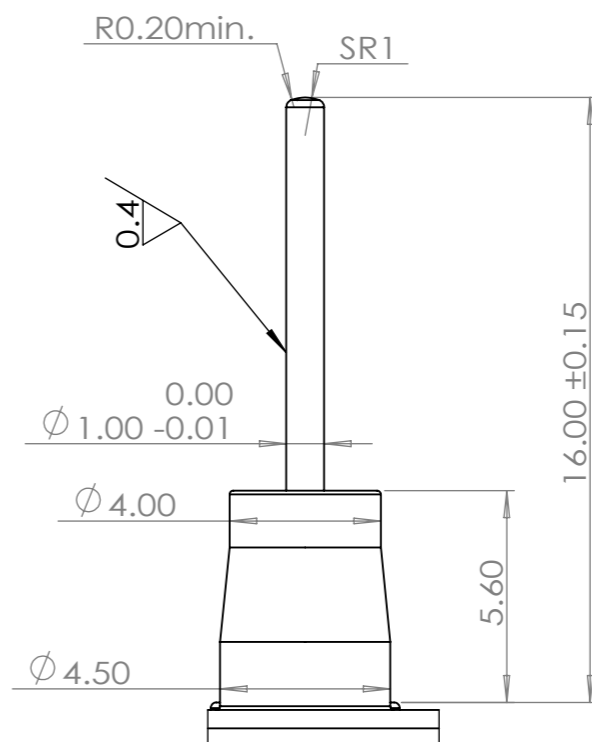

A (5 : 1)

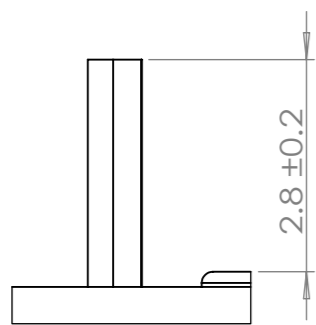

E (10 : 1)

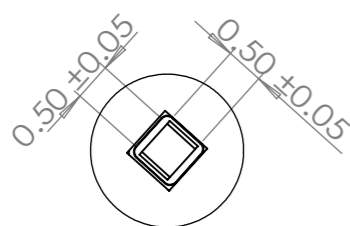

F (10 : 1)

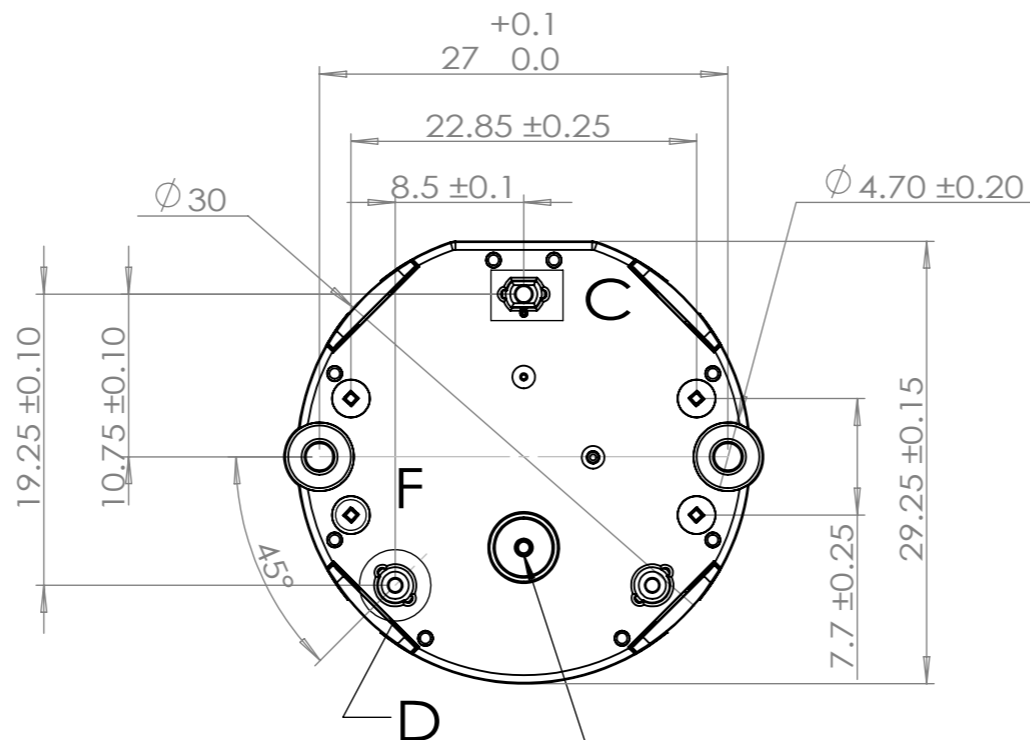

ϕ 0.05 X Y

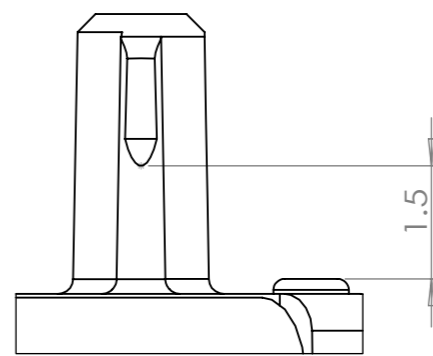

B (10 : 1)



1.6

SPECIFICATIONS:

Housing:
 -Material:PC
 -Colour:Black
 -Hold force clips:85N max

Shaft:
 -Material:Stainless Steel
 -Axialforce(stake-on):150N max
 -Axial pull force:70N max
 -Radial force:12N max
 -External Torque: 40mNm Max
 -Rotation Angle:315°

EI confaces
 -Material:Copper Alloy
 -Coil:el.resistance 260Ω
 Undim.Radio R0.05~R0.10
 Undim.Chamfered edges 0.30×45°

圖紙編號 RD-DWA-V32-070-A00	版本 A0	材料	發出日期
產品/零件名稱 Stepper Motor	產品/零件編號 F32-06L	JDE 編號	圖紙尺寸 A3
項目名稱 F32-06L		單位 mm	制圖 Sam
未注公差: 尺寸以mm為單位 x.x = +/- 0.10 x.xx = +/- 0.03 角度以°為單位 x.x = +/- 1° x.xx = +/- 0.5°		批准	
 Hong Kong VID Company Limited A member of Wellgain Group			